

THIS DRAWING IS UNPUBLISHED. RELEASED FOR PUBLICATION
 © COPYRIGHT - By - ALL RIGHTS RESERVED.

LOC	DIST	REVISIONS					
GP	00	P	LTR	DESCRIPTION	DATE	DWN	APVD
		A		REVISED PER ECO-14-011808	12AUG2014	AP	SB

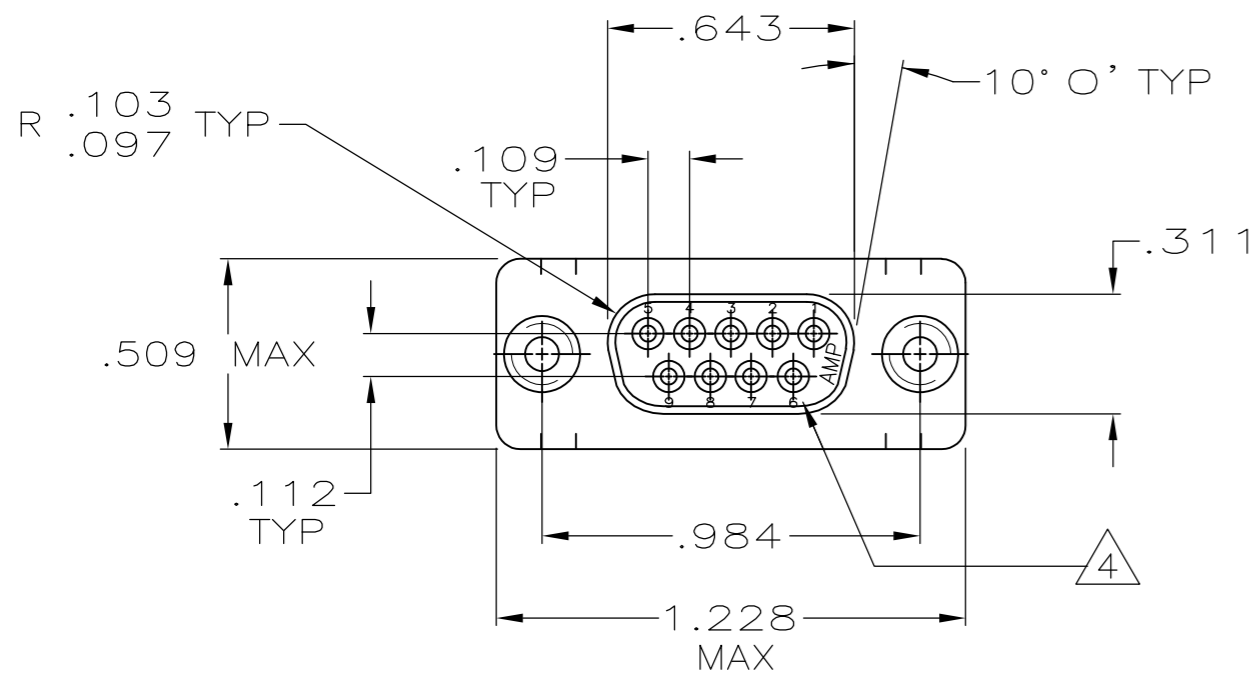

RECEPTACLE CONNECTOR ¹
 INSERTS: GLASS-FILLED PBT OR
 GLASS-FILLED NYLON,
 UL94V-0 RATED.
 COLOR: BLACK.
 SHELLS: STEEL PER ASTM A109
 .000200 MIN TIN PLATE OVER
 .000100 MIN COPPER UNDERPLATE

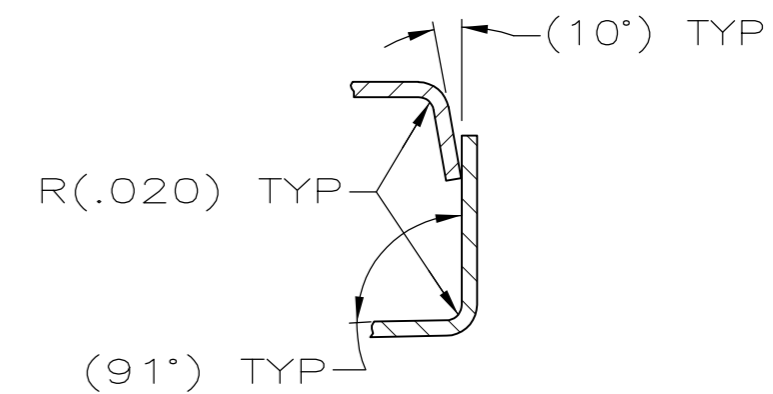

SECTION D-D
 SCALE 4:1

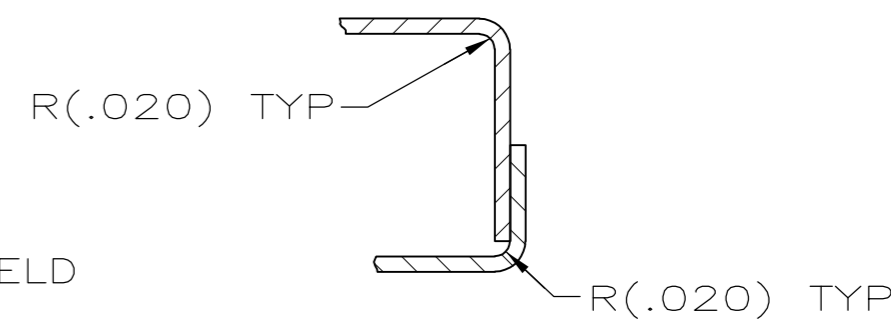
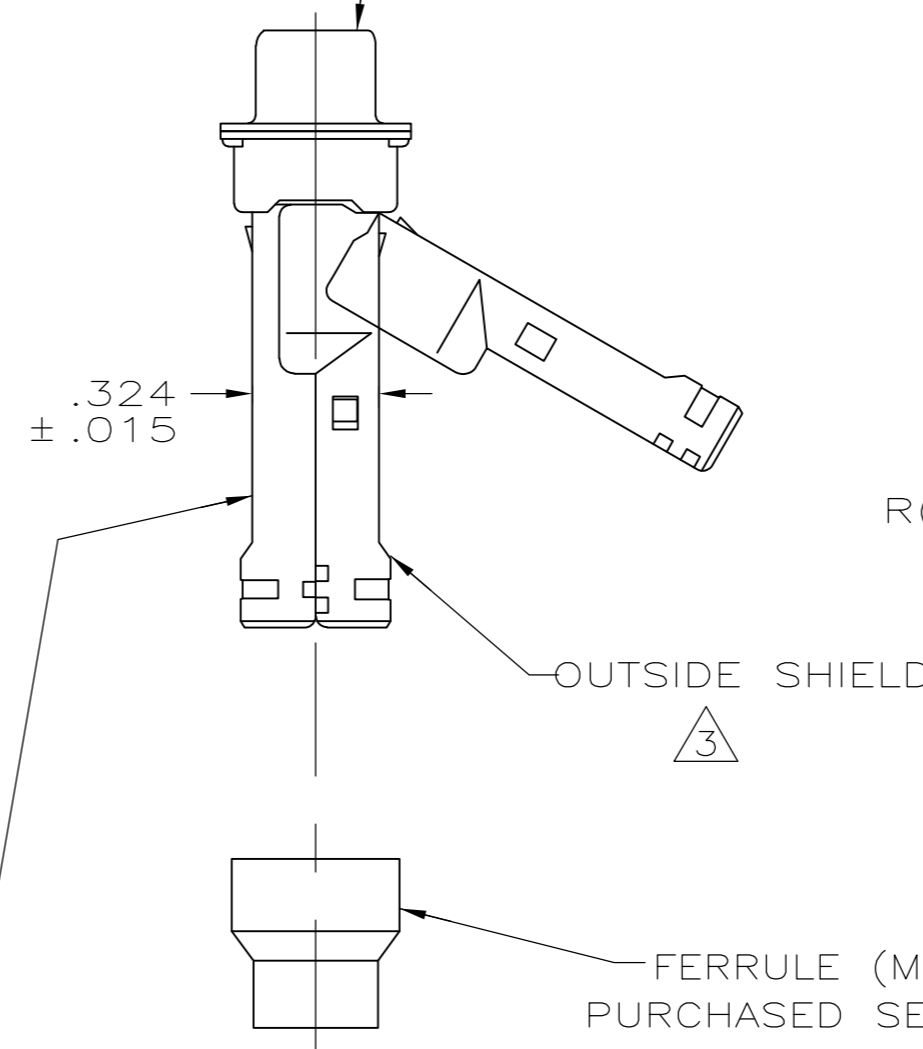
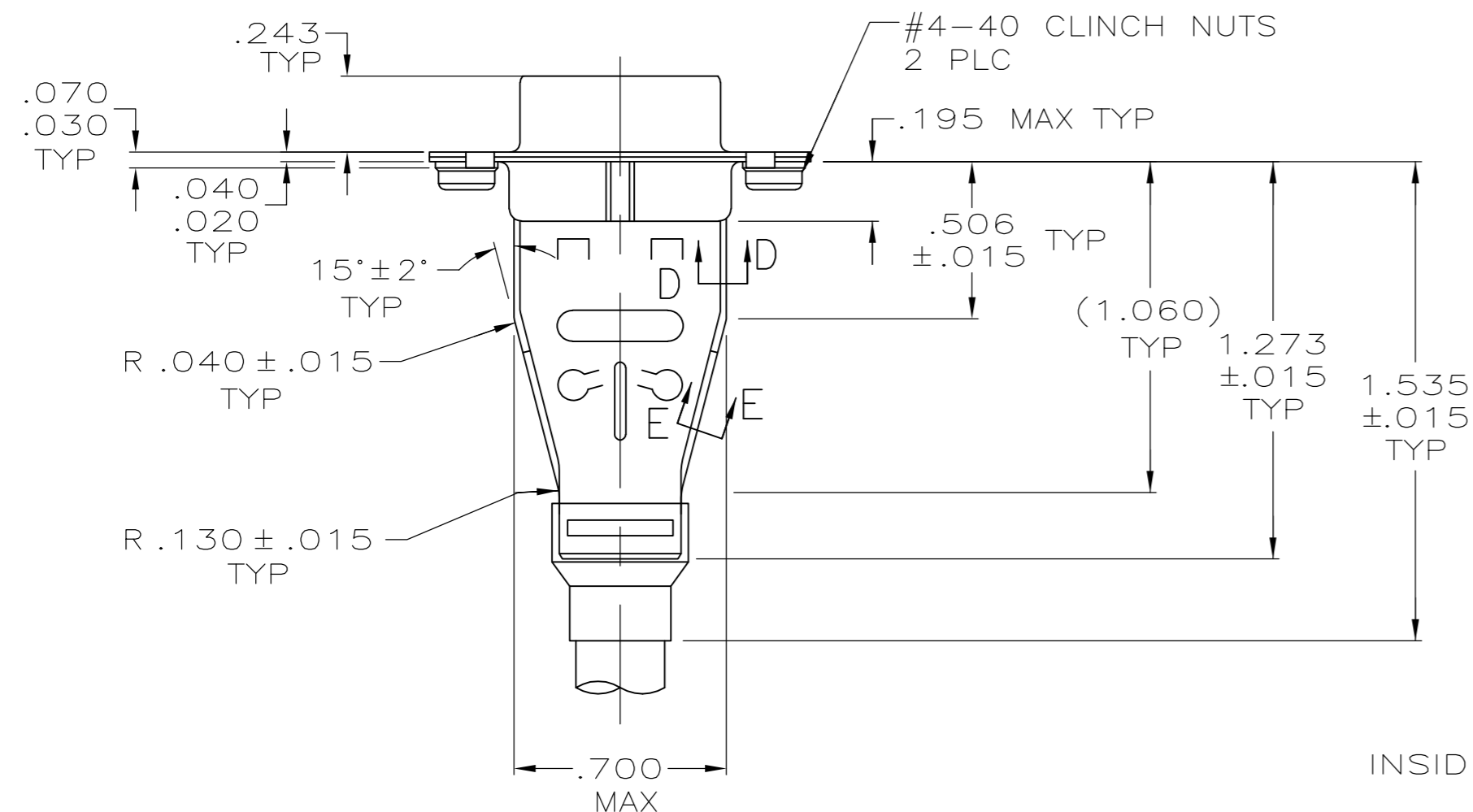

SECTION E-E
 SCALE 4:1

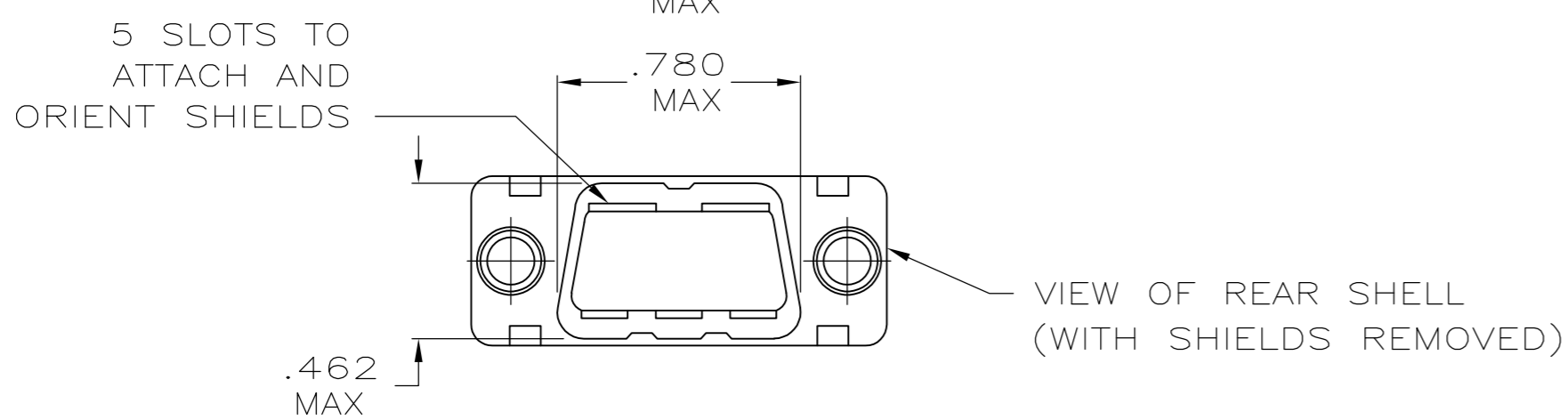

- ¹ RECEPTACLE ACCEPTS SIZE 20 SOCKET CONTACTS (CONTACTS MUST BE ORDERED SEPARATELY)
- 2 ALL PARTS SHIPPED UNASSEMBLED, EACH PART INDIVIDUALLY BULK PACKED.
- ³ SHIELDS: MATERIAL—.020 THICK STEEL, .000200 MIN TIN PLATE OVER .000100 MIN COPPER UNDERPLATE.
- ⁴ RAISED CAVITY IDENTIFICATION AND AMP TRADEMARK.

5748536-1
 PART NUMBER

THIS DRAWING IS A CONTROLLED DOCUMENT.		DWN 11-11-04 G. ATTADIA - DOCK5			114-40030		RESTRICTED TO		
DIMENSIONS: INCHES		CHK 11-11-04 J. GERACE			NAME		KIT, RCPT, SHIELDING HARDWARE, 9 POSN, SIZE 1, W/CLINCH NUTS, AMPLIMITE HDP-20		-
TOLERANCES UNLESS OTHERWISE SPECIFIED:		APVD 11-11-04 M. WALMSLEY	PRODUCT SPEC		114-40030		RESTRICTED TO		
0 PLC ± -		APPLICATION SPEC		SIZE		CAGE CODE		DRAWING NO	
1 PLC ± -		114-40030		A2		00779		C=5748536	
2 PLC ± -		WEIGHT		SCALE		SHEET		REV	
3 PLC ± .005		-		2:1		1 of 1		A	
4 PLC ± -		RESTRICTED CUSTOMER							
ANGLES ± 0° 30'									
FINISH									
SEE CALL OUT ³									